

SLIDING WATERTIGHT DOOR, HI-SKD-YACHT-WT-2 PNEUMATIC OR ELECTRIC OPERATED

Approval: MCA Code of Practice for Safety of Large Commercial Sailing and Motor Vessels, up to 80 m Load Line Length
Watertightness: 4 meters water column from either side.
Fire class: Non fire rated/Lower sill version



STANDARD SPECIFICATION

Doorleaf: 54 mm thick, 2 mm steel skins, insulation core. Incl. front edge safety strip.

Frame: 3 mm pressed profile, welded to the bulkhead. Complete with track, swing trolleys, brackets and steering guides.

Reduced head measurement: 274 mm.

Sill: 3 mm pressed profile.

Reduced sill height: 72 mm.

Seal arrangement: Adjustable seal holder with chloroprene rubber seal.

Finish: Door leaf and frame galvanized and primed.

Hardware: Locking arrangement and emergency opening device.

Power operation: Pneumatic or electric controls.

Max. size: 1400 mm width.

Weight: Doorleaf and frame $\approx 160 \text{ kg/m}^2$, excluding pneumatic or electric controls.

Safety features: Door front edge safety strip. Reserve air reservoirs/back up batteries. Emergency opening device.

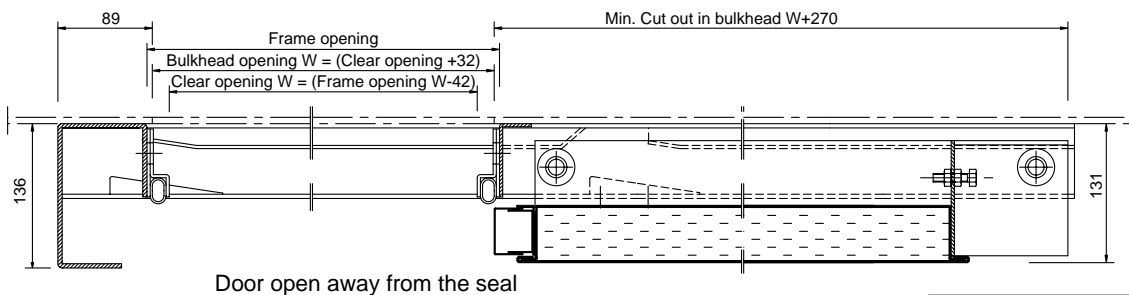
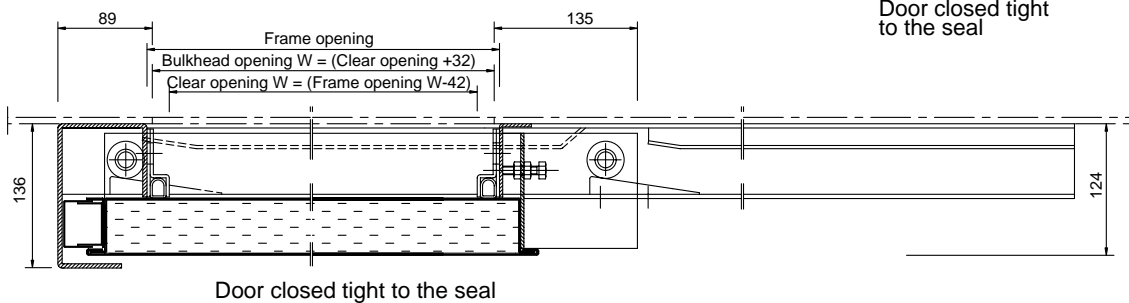
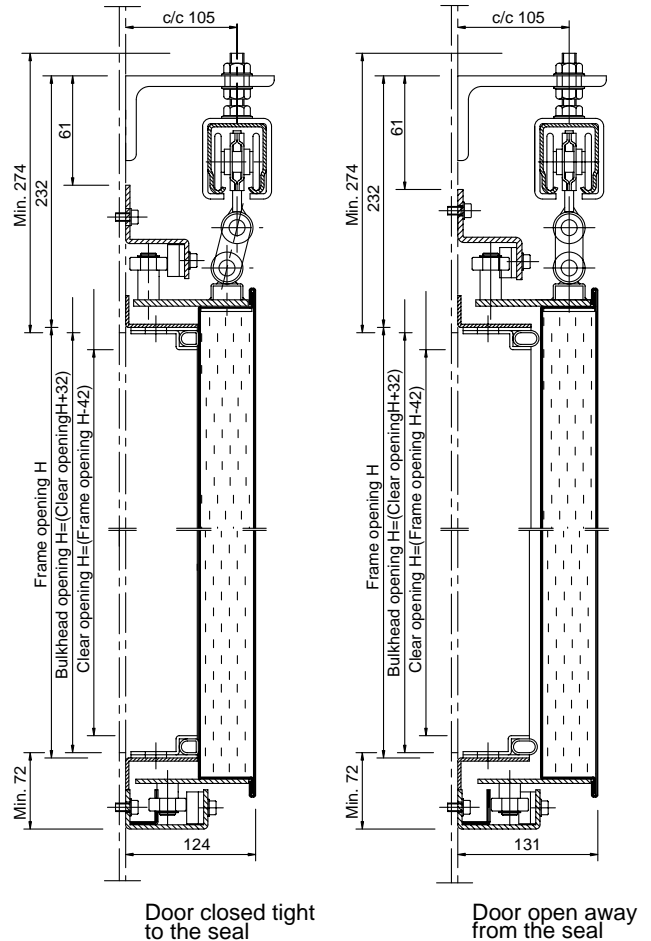

SPECIAL FACTS

- Optional features:** Data sheet MOAS
- Pneumatic control:** Data sheet MP1
- Electric control:** Data sheet ME1